

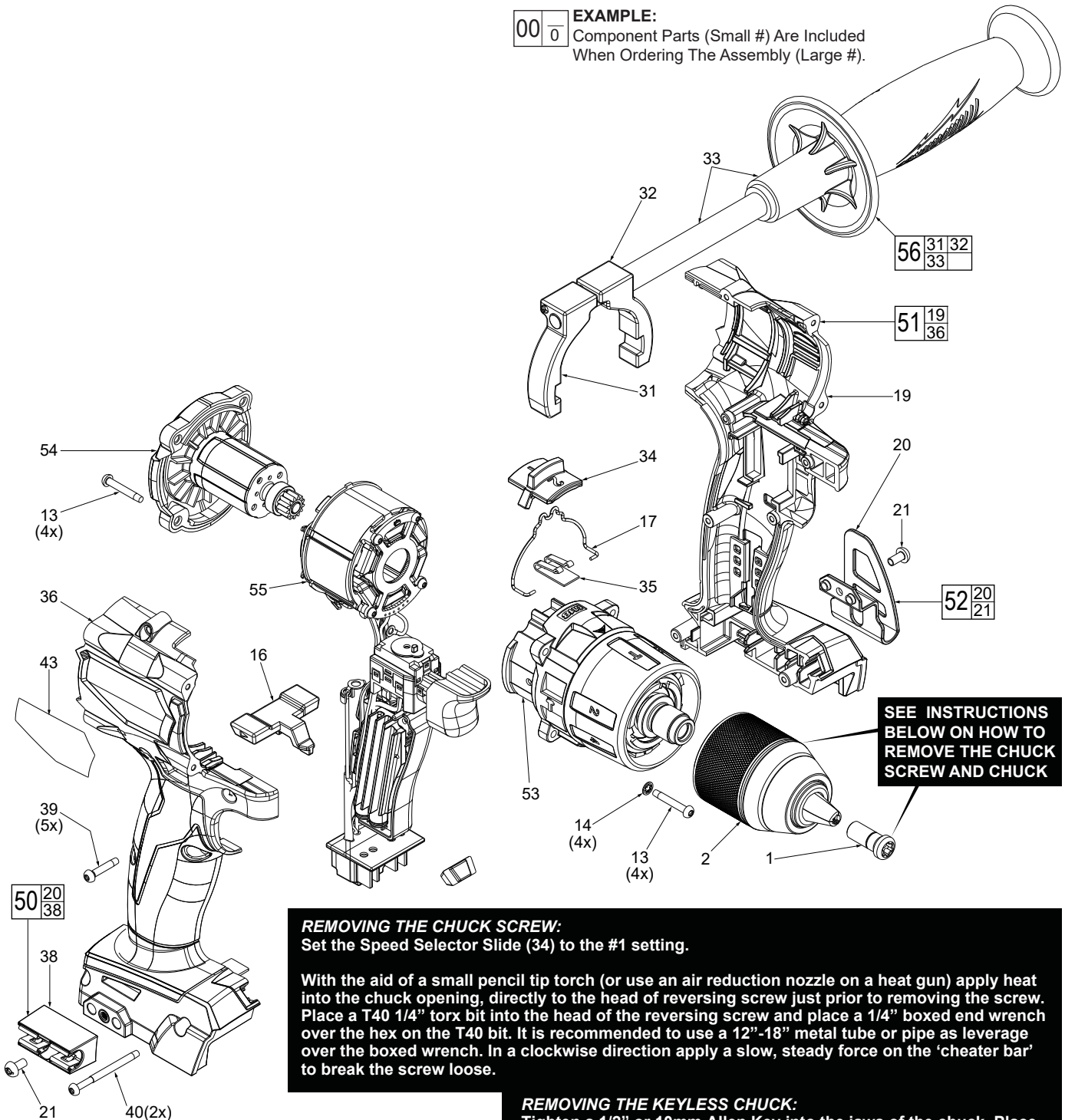

SERVICE PARTS LIST

SPECIFY CATALOG NO. AND SERIAL NO. WHEN ORDERING PARTS		REVISED BULLETIN	DATE
M18 GEN3 FUEL Brushless Hammer Drill 13mm			Jan. 2018
MODEL NO. M18FPD2-0	2804-20	WIRING INSTRUCTION SEE PAGE 2	

EXAMPLE:
 Component Parts (Small #) Are Included
 When Ordering The Assembly (Large #).



REMOVING THE CHUCK SCREW:
 Set the Speed Selector Slide (34) to the #1 setting.

With the aid of a small pencil tip torch (or use an air reduction nozzle on a heat gun) apply heat into the chuck opening, directly to the head of reversing screw just prior to removing the screw. Place a T40 1/4" torx bit into the head of the reversing screw and place a 1/4" boxed end wrench over the hex on the T40 bit. It is recommended to use a 12"-18" metal tube or pipe as leverage over the boxed wrench. In a clockwise direction apply a slow, steady force on the 'cheater bar' to break the screw loose.

REMOVING THE KEYLESS CHUCK:
 Tighten a 1/2" or 10mm Allen Key into the jaws of the chuck. Place the tool into a vise with soft jaws (this will require that you remove the belt clip from the tool). It is recommended to use a 12"-18" metal tube or pipe as leverage over the allen key. In a counter-clockwise direction apply a slow, steady force on the 'cheater bar' to break the chuck loose.

INSTALLING NEW CHUCK AND SCREW:
 Torque Chuck to 1095 kg/cm (950.418 in/lbs or 28.93 ft/lbs)
 Torque Screw to 461 kg/cm (400.130 in/lbs or 33.34 ft/lbs)



Connect ground wire terminal to gear case as shown.

Connector terminals joining gear case assembly to PCBA of the electronics assembly are to be tucked into channel as shown with wires placed down into wire traps.

Watch for pinched wires here.

Be sure that all mechanical and electrical components are placed firmly and squarely in the corresponding cavities of left housing half.

Be very careful and make sure that all wires and the wire ribbon are placed firmly down in wire channels and traps.

Make sure there are no interferences when installing the right housing half.



ATTENTION
OBSERVE PRECAUTIONS
FOR HANDLING
ELECTROSTATIC
SENSITIVE
DEVICES